



D8 D6

OFF-HIGHWAY MULTI-VIEW DUMPER TRUCKS



THE MOST COMPACT



D8

D6

DATI GENERALI		D8	D6
Poertata massima	kg	8.000	6.000
Capacità cassone livello acqua	l	3.200	3.200
Capacità cassone raso	l	4.600	4.600
Capacità cassone colmo	l	6.100	6.100
Sistema di scarico		Posteriore	Posteriore
Posto guida		Reversibile - Dual View	Reversibile - Dual View
Telaio		Fisso	Fisso
Peso a vuoto	kg	5.100	5.100
Trasmissione		Idrostatica	Idrostatica
Cabina		Rops-Fops	Rops-Fops
*MOTORE			
Marca		Yanmar	Yanmar
Modello		4TNV98CT-NYI2D	4TNV98CT-NYI2D
Potenza	kW	53,7	53,7
GUIDA			
Velocità massima	km/h	25 (40 opt.)	25 (40 opt.)
Pendenza superabile	%	50	50
Raggio di sterzata	mm	4400	4400
Trazione		AWS	AWS
Pneumatici		12.5/80-18 16 PR	12.5/80-18 16 PR
Bloccaggio oscillazione assale		Optional	Optional
IMPIANTO IDRAULICO			
Circuito idraulico		Pompa doppia ad ingranaggi	Pompa doppia ad ingranaggi
Pressione di lavoro	bar	180	180
IMPIANTO ELETTRICO			
Motorino di avviamento	V/kW	12/3	12/3
Batteria	V/Ah	12/110	12/110
CAPACITA' SERBATOIO			
Combustibile	l	125	125
Idraulico	l	125	125
FRENI			
Servizio		Idraulico agente su entrambi gli assali	
Sosta		Idraulico agente su ll'assale posteriore	
OMOLOGAZIONI			
Omologazione stradale (Italiana)		Si	Si

*Disponibilità di motore Stage IIIA

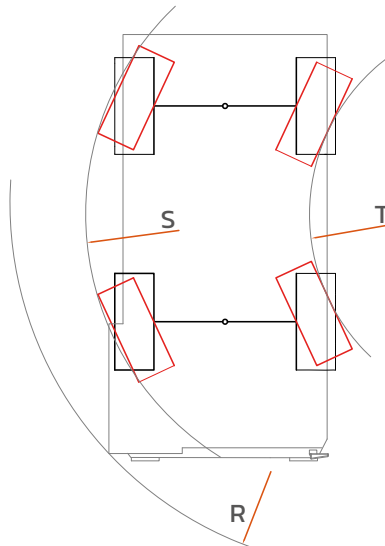
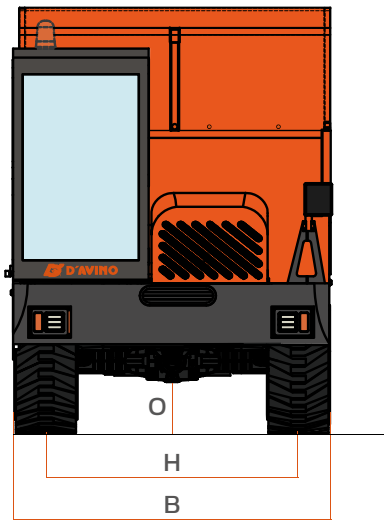
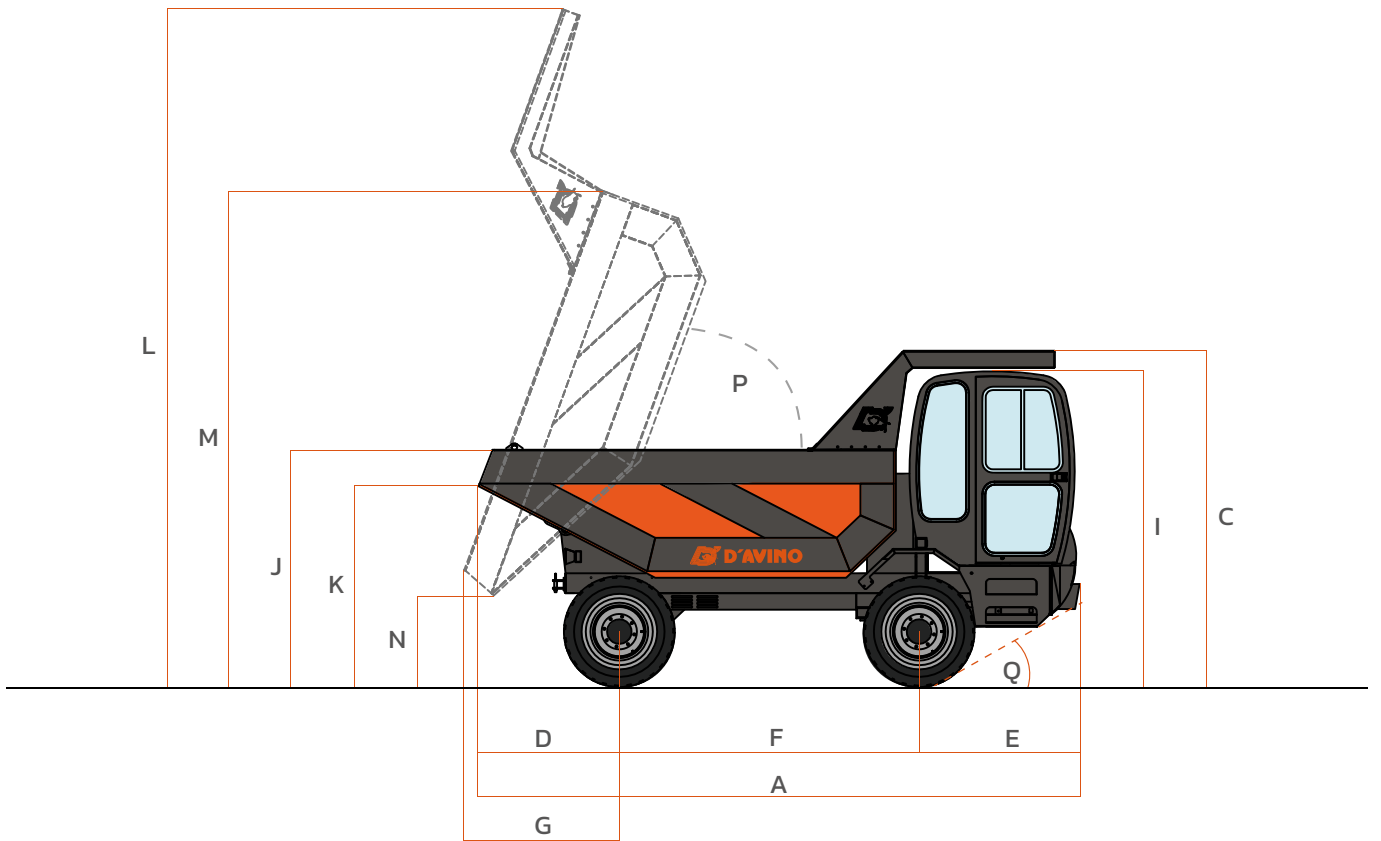

	D8	D6
A	4645	4645
B	2000	2000
C	3170	3170
D	1230	1230
E	1285	1285
F	2130	2130
G	1490	1490
H	1665	1665
I	2780	2780
J	2280	2280
K	1865	1865
L	5530	5530
M	3560	3560
N	880	880
O	300	300
P	70°	70°
Q	31°	31°
R	4400	4400
S	4000	4000
T	2000	2000



AMOG srl | I-80031 Brusciano (NA) | Tel. +39 081 658 8361 | sales@davinogroup.biz

davinodumper.com